



**SAN JOAQUIN COUNTY
PURCHASING AND SUPPORT SERVICES
PURCHASING DIVISION**

**David M. Louis, C.P.M., CPPO, CPPB
Director**

**Jon Drake, C.P.M.
Deputy Director**

January 25, 2012

TO: ALL PROSPECTIVE BIDDERS

RE: Request for Bid No. 6775
Tandem Axle Toilet Trailer

Ladies and Gentlemen:

Enclosed please find an invitation to bid with a bid form and product specification.

Sealed responses are to be received no later than **2:00 PM, PST, Wednesday, February 22, 2012**. Please return your Bid in a sealed envelope with the Bid number and the date and time of bid opening.

Mail or deliver your response by the above date and time to the following address:

**San Joaquin County
Purchasing and Support Services
County Administration Building
44 N. San Joaquin Street, Suite 540
Stockton, CA95202**

****PRE-BID CONFERENCE****

There will be a pre-bid conference at **9:00 AM (Sharp) on Tuesday, January 31, 2012**. The conference will begin at the **Public Works Department, Channel Maintenance Office, 1810 E. Hazelton Avenue, Stockton CA 95205**. This will be your only opportunity to examine the County's current tandem axle toilet trailer .

If you have any further questions, please contact me at (209) 468-9388 or by Email at nfranco@sjgov.org

.

Sincerely,

Norma Franco
Deputy Purchasing Agent

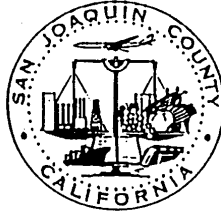

BID # 6775

Tandem Axle Toilet Trailer

COUNTY OF SAN JOAQUIN

44 N. San Joaquin Street, Suite 540
STOCKTON, CA. 95202

FOR: Public Works Department
Channel Maintenance Division
Norma Franco, (209) 468-9388, nfranco@sigov.org

KEY ACTION EVENTS AND DATES

Listed below are the events and dates for this Request for Bid. All dates are predicted on the issue date of the Request for Bid.

EVENT #	DESCRIPTION	DATE
1.	Release of Request for Bid	Wednesday January 25, 2012
2.	Pre-Bid Conference Channel Maintenance Main Office (209) 468-9698 1810 E. Hazelton Avenue Stockton CA 95205	Tuesday 9:00 AM PST January 31, 2012
2.	Last Day for contractors to submit questions (For clarification prior to submitted Bid)	Thursday, 5:00 PM PST February 2, 2012
3.	Last day for County to answer questions	Tuesday, 5:00 PM PST February 7, 2012
4.	Bid is due no later than	Wednesday 2:00 PM PST February 22, 2012
5.	Award of Contract	TBA

INSTRUCTION TO BIDDERS

Submittal of Bids:

Sealed bids will be received at the Office of the Purchasing Agent at 44 N. San Joaquin Street, Suite 540, Stockton, CA 95202-2930 until **2:00, PM, PST, Wednesday, February 22, 2012** and will be publicly opened at that time.

ALL MAIL PROPOSALS SHALL BE ADDRESSED AS FOLLOWS:

Bid No. **6775**
Purchasing Agent
County of San Joaquin
Administration Building
44 N. San Joaquin Street, Suite 540
Stockton, CA95202

The envelopes shall also have stated therein the name and address of the submitting firm.

HAND DELIVERED COURIER OR PACKAGED DELIVERY SERVICE SHALL BE DELIVERED DIRECTLY TO:

Purchasing Division
44 N. San Joaquin Street, Suite 540
Stockton, CA95202

BIDS WILL NOT BE ACCEPTED THEREAFTER. ALL BIDS RECEIVED AFTER SAID TIME AND DATE WILL BE TIME-STAMPED AND RETURNED UNOPENED TO THE BIDDER.

THE COUNTY WILL NOT ACCEPT BIDS SUBMITTED BY FAX OR BY EMAIL

QUESTIONNAIRE

**WARRANTY & SERVICE LOCATION:
(*BIDDER TO COMPLETE*):**

(Failure to furnish this information will be cause for rejection of bid.) State the warranty and/or guarantee provisions applicable to this equipment or attach warranty form with your bid.

State specific location where service and/or maintenance can be obtained.

GENERAL REQUIREMENTS

1. COMPARISON OF BIDS:

Award, if any, will be made to the vendor(s) offering equipment, price, service, delivery and support deemed to be to the best advantage of the County of San Joaquin. The County Purchasing Agent shall be the sole judge in making this determination.

The County of San Joaquin has a 5% local vendor preference; however the preference shall not exceed \$7,500.00 per bid. **To qualify for this Local Vendor Preference, the “Local Vendor Preference Certification” page, included in this solicitation, must be signed and accompany each bid submittal.** Click on the link below to view San Joaquin County’s Policy and Procedures.

<http://www.sjgov.org/SupportServ/dynamic.aspx?id=10217>

2. RIGHT TO REJECT BIDS:

The County reserves the right to reject any and all bids and to waive informalities or irregularities in bids.

3. SAN JOAQUIN COUNTY GREEN PURCHASING POLICY:

San Joaquin County has a Green Purchasing Policy, please click on the link to view.

<http://www.sjgov.org/SupportServ/dynamic.aspx?id=10128>

4. BASIS FOR SELECTION AND CONDITIONS

The responsiveness, competency and responsibility of bidders and of their proposed subcontractors will be considered in making the award of contract. Any bidder before being awarded a contract may be required to furnish evidence satisfactory to the County that bidder and their proposed subcontractors have sufficient means and experience in the type of work called for to assure completion of the contract in a satisfactory manner. The County reserves the right to reject the bid of any bidders as not responsible and not qualified to do the particular work under consideration who have previously failed to perform properly or to complete on time contracts with the County of a nature similar to this project. Other factors that may be considered by the County to determine a responsible bid and the overall capability of the bidder to satisfactorily complete the work under consideration may include, but are not limited to: insufficient experience, experience on other public projects, experience doing the same type of work, length of tenure and capacity with bonding or insurance company, financial stability, and whether a bidder has been terminated on other projects.

A responsive bid is one that meets all terms, conditions, and specifications of the bid. The bid must comply with the content requirements of the bid documents. The bidder must perform and do what the bid documents and contract required and said they must

do, whether it be pricing in a certain way, attending a mandatory pre-bid conference, providing bonds, etc. Other examples where a bid might be declared and found to be non-responsive include:

- Bid is substantially incomplete
- Bid is not signed
- Bid is delivered late
- No acknowledgement of critical addenda
- Significant discrepancies appear in the response

A responsive bid conforms to bid specifications. However, a bid which substantially conforms, though not strictly responsive, to a call for bids may be accepted if the variance cannot have affected the amount of the bid or given a bidder an advantage or benefit not allowed other bidders or, in other words, if the variance is inconsequential. The County reserves the right to reject any and all bids or alternatives and waive any informality or irregularity in the bids or in the bidding, and to determine responsiveness and responsibility of bidder, including but not limited to those areas mentioned above.

5. ADDENDUM(S):

Vendors are to indicate acknowledgement, sign, and return addendums with their response. The County reserves the right to reject any response(s) deemed to be non-responsive.

6. SUBMITTALS:

Bidders shall submit literature that fully describes items on which they are bidding, not later than the opening date of this bid. Any and all literature submitted must be stamped with vendor's name and address. **Bidders must submit one (1) original, clearly marked "Original" and two (2) copies, clearly marked "COPY" of each bid and all literature.**

7. DEMONSTRATION:

Upon request by County of San Joaquin, bidder shall provide a demonstration unit as stated in bidder's offer, to the Public Works Department, Channel Maintenance Division, for a period of time not to exceed two (2) working days. Failure to provide a demonstration unit within ten (10) working days of the County's request may be cause for rejection of bidder's offer.

8. MAINTENANCE:

The successful bidder shall provide all tools or minor equipment specifically required to maintain equipment supplied. Bidder shall list any special oils, additives or other lubricants needed for maintenance of equipment supplied.

9. PRE-DELIVERY AND INSPECTION:

Prior to delivery, equipment shall be completely inspected and serviced by the delivering dealer and/or the manufacturer's pre-delivery service center.

The County will inspect equipment, upon delivery, for workmanship, appearance, proper functioning of all equipment and systems, and conformance to all requirements of bid specifications. In the event deficiencies are detected, the equipment will be rejected and it shall be the delivering dealer's responsibility to pick up the equipment, make the necessary corrections and re-deliver the equipment for a re-inspection and acceptance.

10. PAYMENT:

The bidder agrees to provide equipment and other requirements as stated in this Request for Bid. The County agrees to pay bidder according to the terms and conditions stated in the contract or purchase order.

Should deficiencies be detected in equipment supplied, payment, or the commencement of a discount period, (if applicable) will not be made until the defects are corrected and accepted by the County of San Joaquin.

11. PAYMENT DISCOUNTS:

Any discount offered by the bidder must allow for payment after receipt and acceptance of material/equipment and correct invoice, whichever is later. In no case will discount be considered in the evaluation of bids, which require payment in less than thirty (30) days.

12. WARRANTY:

Equipment shall be warranted against defects in materials and workmanship. The bidder shall make all adjustments without cost to the County within manufacturer's warranty period. Vendor shall pick up equipment at the County departments, when required adjustments so indicate, and return repaired unit to County department.

13. DELIVERY INSTRUCTIONS:

All equipment shall be bid - FOB DESTINATION / FULL FREIGHT ALLOWED - delivered to the following address:

San Joaquin County
Equipment Shop
444 S Wilson Way
StocktonCA95205

Call Dan McCann, (209) 468-3106) 10 calendar days prior to delivery.

14. LICENSING:

The County of San Joaquin will license all vehicles. Successful bidder shall furnish to the County the following documents, properly filled out, at the time the equipment/vehicle is delivered:

1. "Dealer's Report of Sale"
2. "Application for Exempt Registration"
3. "Manufacturer's Certificate of Origin"
4. "Certified Weigh-master's Certificate"
5. "Original invoice at time of delivery"

Payment will not be made until all documents are received.

The address on these documents shall read as follows:

County of San Joaquin
44 N. San Joaquin Street, Suite 540
Stockton, CA 95202

15. DEVIATIONS:

Failure on the part of the bidder to comply with all requirements and conditions of the price request and this specification may be cause for rejection of bid. No exceptions to, or deviations from, this specification will be considered unless the bidder in the designated places specifically states each exception or deviation. If no exceptions or deviations are shown, the bidder will be required to furnish equipment exactly as specified herein. The burden of proof of compliance with this specification is the responsibility of the bidder.

While it is not the intent of these specifications to eliminate prospective bidders, bidders must note any deviations from the specifications in order that the County may evaluate the equipment.

16. VEHICLE CODE REFERENCED DOCUMENTS:

Vehicles/equipment provided must meet all current regulations of the agencies listed below. These regulations are incorporated herein by reference and made part of the specifications to the extent they are applicable.

1. Department of Transportation Federal Highway Administration.
2. Federal Motor Vehicle Safety Regulations and Standards.
3. OSHA Standards.
4. State of California Safety Regulations.
5. California Air Pollution Control Board
6. California Bureau of Motor Carrier Safety.
7. Title XIII, Motor Vehicles Division 2, Chap 2, Lighting Equipment.
8. Any other vehicle or equipment legal requirements that may apply.

17. EQUIPMENT STANDARDS:

The equipment supplied shall be new (unused), current model year production and equal in style, quality and appointments to those offered to the general public. The equipment shall be supplied with all accessories as considered standard equipment for make and model specified. Unit(s) shall be delivered complete and functionally ready to operate. Unit(s) offered shall meet the following MINIMUM or specific specifications.

18. CONTACT:

Contact Norma Franco, by fax (209) 468-3393 or by Email: nfranco@sjgov.org with any questions or requests for additional information.

EQUIPMENT SPECIFICATIONS

TANDEM AXLE TOILET TRAILER

**Indicate in this column
the actual equipment
specification for the bid
unit that is proposed to
meet this specification.**

SPECIFICATIONS:

1. TRAILER:

- A. The trailer frame shall be fabricated from welded structural "C" channel, riveted or bolted construction will not be accepted. The trailer frame shall consist of two (2) longitudinal members, front and rear cross members and at least one (1) intermediate cross member, fabricated from ¼ steel, minimum. The tongue shall be fabricated from the same material as the frame with a "V" shaped cross brace from the ends of the frame to the hitch. The overall width of the completed trailer shall not exceed 72 inches including tires and fenders. The entire length of the unit shall be approximately 16feet and not exceed 18 feet. The finished unit shall be of adequate design and strength for the use intended, and shall be constructed such that it can be safely towed at legal highway speeds of 55 miles per hour, when loaded to its maximum rated capacity. The completed specified unit shall have a Gross Vehicle Weight Rating between 4,900 lbs. and 5,000 lbs. and must have a minimum 2000 pound payload capacity.

2. TOILET ENCLOSURE

- A. The enclosure shall be fabricated from corrosion resistant weatherproof material with a minimum service life of ten years and capable of being towed without imploding. The enclosure shall be one piece molded without rivets and be Orange or White. The enclosure shall be vented with screens or louvers covering all vents. The enclosure shall have one (1) towel holder (for single fold 9" x 10" paper towels). Holders for two (2) rolls of toilet tissue shall be furnished and installed. Tissue holders shall be of a type, which prevents tissue from unrolling during transport. The enclosure shall be securely mounted to the trailer with bolts and reinforcement plates of adequate size and strength. The enclosure may not be mounted on top of a wooden platform. Any steel sheathing underneath the enclosure shall be moisture sealed and protected. The overall unit shall be installed as low as possible to minimize wind resistance. The door of the enclosure shall

Indicate in this column
the actual equipment
specification for the bid
unit that is proposed to
meet this specification.

SPECIFICATIONS:

be right hand hinged and permit entry from the right or curb side of the trailer, have a handle and be lockable from the interior. The door shall be designed to assure it will not open while the unit is being towed, without the use of a latch to secure the door. There shall be a means to secure the door in the open position to allow for cleaning. All trailers on a single order shall be keyed alike.

- B. Each enclosure shall have a LED strobe light mounted on the rear, upper left corner of the enclosure installed per manufacturer's recommendations. The mounting shall be fully water tight and sealed on both sides. The wiring shall be of sufficient gauge and routed outside the enclosure in a UV protected conduit, mounted with rubberized Zoom clamps. The power source for this light shall be the number 4 pin on the 7 wire trailer wiring plug. Each light shall be properly grounded and connected to the number 1 on the 7 wire trailer wiring plug. There shall be a non-skid type entry platform at the front of the toilet enclosure. Steps and handrails shall be installed, as necessary, for a 3 point entry and egress. The design and construction of the unit shall be for entry and egress from the curbside. The brake system shall not interfere with the platform.

3. WASHBASIN& EYE WASH STATION:

- A. A replaceable stainless steel wash basin with a self-closing faucet shall be installed. A liquid soap dispenser shall be installed near the wash basin. The wash basin drain shall incorporate a "P" type trap. The wash basin shall be mounted on the top of the toolbox.
- B. A self-contained eyewash station to be mounted in an easily accessible area near the wash basin. The station shall be located in a manner that facilitates easy access to the station in the event of an emergency. Station to utilize replaceable, sterile, single-use, eyewash solution bottles.

4. WATER/HOLDING TANKS:

- A. A water supply tank shall be furnished with an adequate volume to provide a minimum supply of 15 gallons of fresh water to the wash basin. The fresh water tank shall be suitable for filling with a garden hose. The gray water from the wash basin shall drain into a single waste tank. The capacity of the waste tank shall exceed the capacity

Indicate in this column
the actual equipment
specification for the bid
unit that is proposed to
meet this specification.

SPECIFICATIONS:

of the fresh water tank by a minimum of 15 gallons. An RV type dump system with trap shall be furnished at the street (right) side of the trailer to drain the waste tank. A minimum eight (8) feet length of flexible dump hose shall be furnished with male/female RV type fittings on the ends, to attach to the waste drain and to an extension hose. The hose shall be stored and secured in a separate angled holder under the trailer, or as otherwise deemed acceptable by the customer.

- B. The fresh supply water tank shall be manufactured from opaque polyethylene with UV protection. The tank may be translucent if the tank is fully covered. Tank and lid shall be positively secured and easily removable and replaceable. The supply tank shall be equipped with a sight gauge.
- C. Hoses for tanks shall be weatherproof rubber capable of sustaining pressures of 50psi. The supply hose to the Water Supply Pump shall be non-collapsible. All hoses shall be free from kinks and protected from abrasion when routing through or around metal objects and shall be properly secured using rubberized Zoom clamps. Plumbing on tanks, wash basins, etc. shall be PVC, or non-corrosive metal.

5. TOILET:

- A. The toilet shall be a chemical type with a seat and seat cover. The toilet shall be securely installed in an enclosure near the front of the trailer. The unit system shall incorporate a sealed waste water compartment to minimize objectionable odor in and around the trailer. Normal servicing shall be accomplished without removal of the toilet.

6. TOOL BOX:

- A. A weather tight tool box with minimum dimensions of 42 inches long by 18 inches deep by 28 inches high shall be installed at the forward curb side of the trailer next to the toilet enclosure. The box shall be fabricated from not less than 16 gauge material, have two (2) side opening doors with a cam lock or slam type lockable latch on the primary door and a self-locking spring loaded slam type latch on the second door. The doors shall be weatherproof with seals or interlocking design and construction. The forward door shall be the primary or first opening door. The box shall have one

Indicate in this column
the actual equipment
specification for the bid
unit that is proposed to
meet this specification.

SPECIFICATIONS:

(1) horizontal shelf at mid-height. The outside edges of the shelf shall be rolled to form a retaining, stiffening lip. The bottom of the box and the shelf shall have drain holes at each corner fitted with rubber plugs. There shall be one, five (5) gallon drinking water cooler holder, (round) mounted on the top of the Toolbox. Cooler is not required part of bid.

7. TOOL BINS:

- A. Four (4) open top tool bins shall be installed on the curbside of the trailer. The bins shall begin at the edge of the tool box and extend to the end of the trailer. Each bin shall be 12 inches wide by 24 inches deep by 36 inches high in the front and 48 inches high at the back. Removable dividers between the bins shall be furnished which, when removed, will provide a single tool bin 48 inches wide. The dividers shall be constructed from a minimum of 1 inch thick marine grade plywood.
- B. The tool bin frames shall be constructed from a minimum 1 inch x 1 inch x 1/8 Inch steel angle and 2 inch x 1/8 inch steel flat bar. The sides of the bins from the trailer floor to a height of 18 inches shall be 12 gauge solid steel panels. The remainder of the sides may be open. The divider wall between the trash/storage bin and the tool bins, from the floor to a minimum height of 4 inches shall be constructed from a minimum of 12 gauge steel.
- C. There shall be a rope loop or hook located at the top corner of each tool bin. Rope loops or hooks are to be installed only on the 48 inch high side of tool bin, not on the 36 inch high side.

8. TRASH/STORAGE BIN:

- A. A trash/storage bin, approximately 7.5 feet long, with sides 38 inches, total height shall comprise the balance of the trailer area. The lowest 18 inches of the sides of this bin shall be constructed from 12 gauge sheet steel. The floor of this bin, from the front of the bin to within 12 inches of the rear of the bin shall be constructed from not less than 10 gauge sheet steel. The remaining 12 inches of floor area shall be constructed from expanded metal of an equal thickness to the floor, for clean-out purposes.
- B. The rear of the trash bin shall have a fold down tailgate approximately 24 inches in height, similar to that on a pickup truck. The gate shall be latched on both sides with steel

Indicate in this column
the actual equipment
specification for the bid
unit that is proposed to
meet this specification.

SPECIFICATIONS:

slide bolts (McMaster-Carr Part #13395A52 or comparable). The gate shall have a minimum 1/4 inch support chains at both ends of the gate. These chains shall be covered with a rubber or plastic hose. The hinge, chains, and gate shall be of sufficient strength to hold up to two operators weighing 250 pounds each. The surface of the tailgate shall be nonskid.

9. CARGO AREA ENCLOSURE:

- A. The entire cargo area shall be enclosed on the sides with an expanded metal mesh. The top of enclosure to be constructed of sheet metal, 12 gauge minimum thickness, with ribbed reinforcements. All edges shall be fully channeled by welding on a minimum 1 inch x 1 inch x 1/4 inch angle iron. The interior height shall be 78 inches. The rear of the trailer shall have double vertically hung doors. The double vertically hung doors shall be securely latched in the closed position similar to the tailgate latches. These doors shall also have a safety latch to secure the door in open position. The curb side door shall open first and independently of the street side door and open without significantly disturbing the cargo loading area. Vertically hung doors shall be easily removable with the use of small hand tools.

- B. The cargo area enclosure shall be equipped with a side door opening on curb side. This door shall securely latch in the closed and open position using hardware similar to the tailgate latches or other approved hardware. This door shall provide for an opening of 36 inches X 36 inches. The door shall be mounted in the 48 to 84 inch height area as measured from level ground.

10. SUSPENSION:

- A. The trailer shall be equipped with a Tandem axle with each axle rated at not less than 2500 lbs. each. The capacity of the axles shall be not less than the GVWR of the trailer and load requirement in Section 1. The axle shall be leaf spring suspension with load equalizing bars. The trailer shall have a minimum 7.5 inches of clearance from level ground to the center of the axle. The frame shall be reinforced as necessary. The axle shall be positioned to allow full suspension travel without interference. There shall be no suspension or axle components below the lowest point of the wheel. The axle shall have a minimum clearance of 7 inches from

Indicate in this column
the actual equipment
specification for the bid
unit that is proposed to
meet this specification.

SPECIFICATIONS:

level ground. Tire clearances shall meet or exceed the requirements of SAE J683 for snow chains.

11. BRAKES:

- A. The trailer shall be equipped with hydraulic surge brakes. The hydraulic surge brake shall have a Yoder or Dico brake actuator, rated at no less than 7000 pounds. The surge brake system shall be provided with a flexible hose at the rear of the brake backing plate connected to the brake system with a bulkhead fitting. The bulkhead fitting shall be securely attached to the trailer frame. The safety brake actuation cable shall have a positive locking safety hook, an S hook is not acceptable. The brake hoses and brake actuator shall be fully protected to prevent damage from when a user steps on or near the actuator. This cover shall be removable to allow for service and repair. The brakes shall have free backing plates. The brakes shall be matched to the spindle size and have braking capacity for the selected axle. The remaining plumbing for the brake system shall be steel mechanical tubing of the proper specification for brake lines securely attached to the trailer frame (not using nyties).

12. WHEELS AND TIRES:

- A. The wheels shall be 5 lugs, 15 inch diameter. The tires shall be tubeless ST215/75/15 with standard highway tread. All wheels and tires furnished on a single order shall be the same make and model. The tires shall be completely mounted on the wheels.
- B. A fender shall cover the full width of each wheel and tire. There shall be a minimum of 2 inches clearance around the circumference of the tire and 1-1/2 inches clearance on the sides of the tire when the trailer is loaded to its full rated capacity. Each fender shall have an inner skirt to protect the trailer from mud and road dirt.

13. HITCH:

- A. The trailer shall be equipped with a lunette towing eye. The towing eye shall be constructed of 1-5/8 inch diameter solid round stock with a 3 inch inside diameter. The lunette eye shall be adjustable from 19 inches to 26 inches in 2 inch increments from ground level while the trailer is in a level position.

Indicate in this column
the actual equipment
specification for the bid
unit that is proposed to
meet this specification.

SPECIFICATIONS:

- B. The axle shall be located on the trailer such that the hitch weight will be between 10% and 15% of the tare weight and also between 10% and 15% of the gross weight of the trailer.
- C. A 1000 pound capacity swing away screw type jack stand with a swivel caster shall be installed on the left side of the tongue.

14. ELECTRICAL EQUIPMENT:

- A. Minimum electrical equipment shall comply with all Federal Motor Vehicle Safety Standards (FMVSS) and State of California Department of Motor Vehicle regulations. Notwithstanding any Federal or State minimum requirements, each unit shall be equipped with two (2) tail-lights, two (2) stop lights, and turn (left and right) signals. All lights shall be light emitting diode (LED) recessed type, mounted in rubber grommets. The tail, stop and turn signal lamps may be in combination (Ref. Truck-Lite #44982R (round); #60885 (oval); with hard coated lens). Grommets shall match the light used. The side marker, clearance, and ICC lamps shall be 2-1/2 inch LED units (Ref. Truck-Lite #10250R, #10250Y and #10700 grommets). Retro-reflective tape reflectors (Ref. Peterson Mfg. #B490R and #849A shall be used where needed to meet FMVSS requirements from Class A reflectors. Mounting holes for lights shall be the proper dimension as recommended by the manufacturer of the light. The holes shall be punched, plasma, or saw cut and finished smooth: torch cut holes are unacceptable.
- B. All wiring installed by the supplier shall be the "UNITIZED" type (Ref. Grote Ultra Blue Seal Trailer Wiring System #1 or comparable.)

15. SAFETY CHAINS:

- A. Two (2) safety chains shall be provided with spring closure hooks. Hooks to extend not less than 24 inches beyond lunette eye.

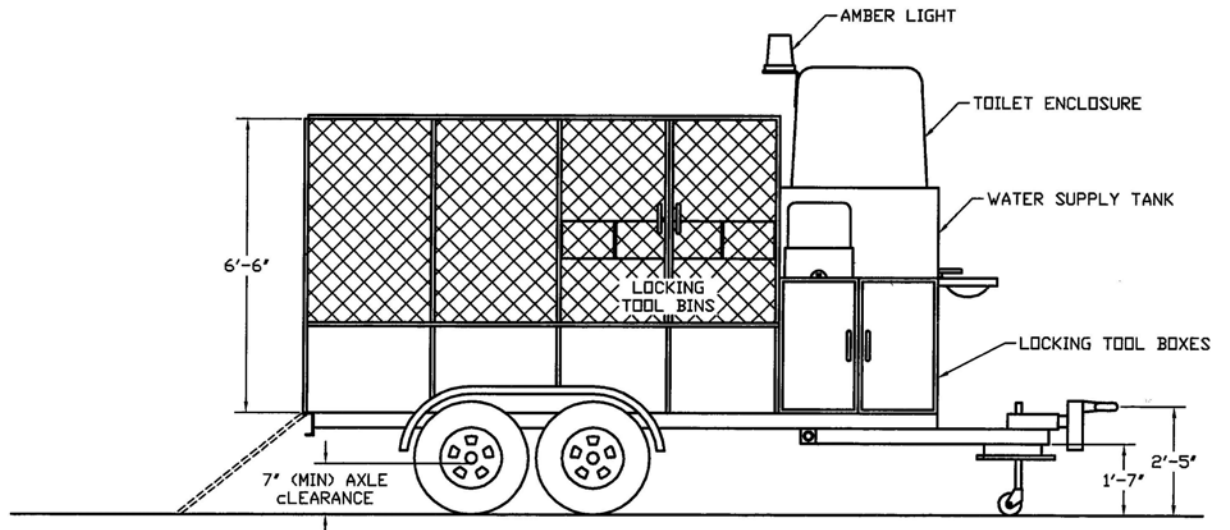
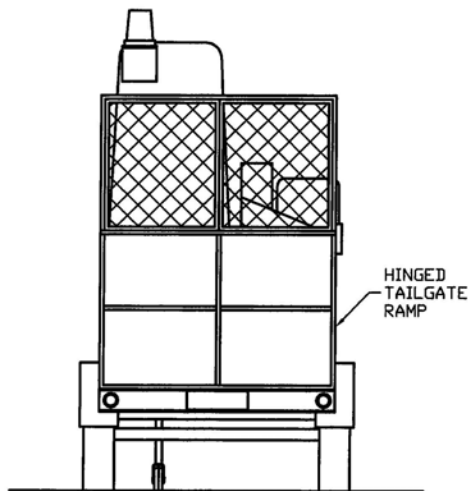
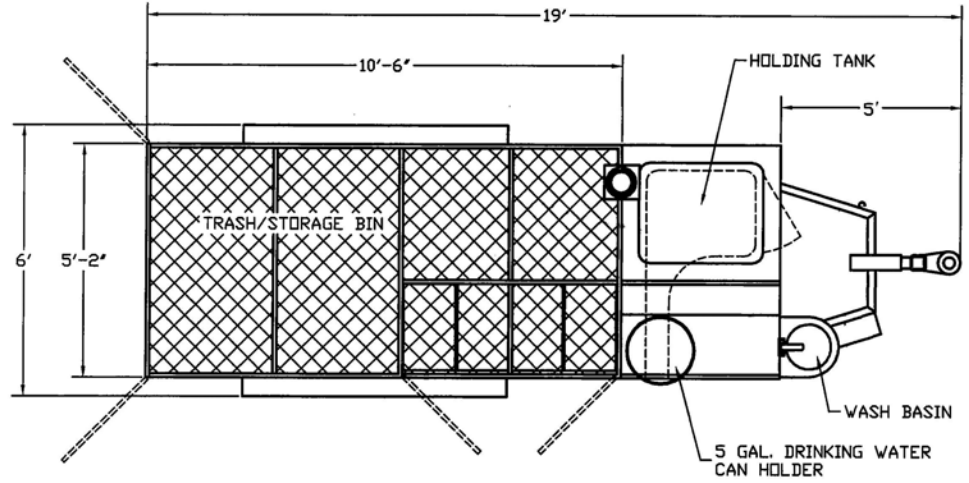

COOPERATIVE / PIGGYBACK CLAUSE

For the term of the Contract and any mutually agreed extensions pursuant to this request for bids/proposals, **at the option of the vendor**, other public agencies or public corporations, including any county, city, town, school district, community college, public utility district or other public corporation or agency within the State of California, may purchase, lease-purchase, or rent the identical items(s) at the same price and upon the same terms and conditions pursuant to any applicable Public Contract or other relative legal Code.

San Joaquin County waives its right to require such other districts and offices to draw their warrants in the favor of the County and agreements, orders, and payments may be made directly between the vendor and the public agency/corporation.

Acceptance or rejection of this clause will not affect the outcome of the bid/proposal.

Piggyback option granted _____

(Vendor please initial)

Piggyback option not granted _____

**This space is ‘
Intentionally left
blank**

BID SHEET

1.	1 ea.	Tandem Axle Toilet Trailer	_____
		8 % sales tax	_____
		TOTAL	_____

Vehicle Manufacturer:

Make: _____

Model: _____ Year: _____

Due Bills will not be accepted.

=====
 No charge for packaging, drayage or any other purpose will be allowed over and above the price quoted on this sheet. The County reserves the right to accept or reject quotations on each item separately or as a whole. Special brands, when named, are only to indicate the standard of quality desired. Firms may quote on their equal. Offerings on other brands, if their equal, will be considered, and brands or descriptions must be plainly stated. The Purchasing Agent reserves the right to reject any and all bids, to waive any informalities or irregularities in the **Bid** and to be the sole judge of the suitability of the product offered.
 =====

The undersigned offers and agrees to furnish any and all items upon which prices are quoted hereon, at the prices set opposite each item and deliver at the designated point(s) specified in the above request.

Delivery will be made in _____ days from receipt of order, except as otherwise indicated.

Pricing valid for 90 days

Discount terms _____ Date _____

Company Name _____

Address _____ City _____ State _____ Zip _____

Telephone _____ Fax _____

E-mail: _____

Authorized Signature _____

Print/Type Name _____